

**CENTRAL MACHINERY**

®

# RABBETING JOINTER - 6"

**Model 30289**

## ASSEMBLY AND OPERATING INFORMATION



3491 Mission Oaks Blvd., Camarillo, CA 93011  
Visit our Web site at <http://www.harborfreight.com>

Copyright© 2001 by Harbor Freight Tools®. All rights reserved. No portion of this manual or any artwork contained herein may be reproduced in any shape or form without the express written consent of Harbor Freight Tools.

**For technical questions please call 1-800-444-3353**

## SPECIFICATIONS

ITEM	DESCRIPTION
Net Weight	160 Lbs.
Front Table Size	22-1/2"
Rear Table Size	19-1/2"
Overall Table Length	42-1/2"
Jointer Size	7-1/2" x 10" x 36"
Fence Size	3-1/2" x 26-3/4"
Rabbeting Ledge	2-7/8"
Cutter Head Size	3"
Cutter Head Speed	4900 to 5900 RPM
Knives	3
Depth of Cut	3/8"
Rabbet Cut	3/8"
Fence Tilt	45° w/Positive Stops at 45° and 90°
Motor	1 HP
Electrical Requirements	110V, 8 AMP, 1 Phase



## SAVE THIS MANUAL

**You will need this manual for the safety warnings and precautions, assembly and operating, cleaning, inspection, and maintenance procedures, parts lists, assembly and wiring diagrams. Keep your invoice with this manual. Write the invoice number on the inside of the front cover. Keep this manual and invoice in a safe and dry place for future reference.**

## GENERAL SAFETY WARNINGS AND PRECAUTIONS

1. **KEEP WORK AREA CLEAN AND DRY.** Cluttered, damp or wet work areas invite injuries.
2. **KEEP CHILDREN AWAY FROM WORK AREA.** Do not allow children to handle this product.
3. **STORE IDLE EQUIPMENT.** When not in use, tools and equipment should be stored in a dry location to inhibit rust. Always lock up tools and equipment and keep out of reach of children.

4. **DO NOT USE THIS PRODUCT IF UNDER THE INFLUENCE OF ALCOHOL OR DRUGS.** Read warning labels on prescriptions to determine if your judgment or reflexes are impaired while taking drugs. If there is any doubt, do not attempt to use this product.
5. **USE EYE, HEARING, AND BREATHING PROTECTION.** Wear ANSI approved safety impact eye glasses, ANSI approved hearing protection, and ANSI approved dust mask or respirator when using this product. ANSI approved safety impact eye glasses, hearing protection, and dust masks and respirators are available from Harbor Freight Tools.
6. **DRESS SAFELY.** Non-skid footwear or safety shoes should be used when working with this product. Do not wear loose clothing or jewelry as they can become caught in moving parts. Wear a protective hair covering to prevent long hair from becoming caught in moving parts. If wearing a long-sleeve shirt, roll sleeves up above elbows.
7. **INDUSTRIAL APPLICATIONS MUST FOLLOW OSHA REQUIREMENTS.**
8. **DO NOT OVERREACH.** Keep proper footing and balance at all times to prevent tripping, falling, back injury, etcetera.
9. **STAY ALERT.** Watch what you are doing at all times. Use common sense. Do not use this product when you are tired or distracted from the job at hand.
10. **CHECK FOR DAMAGED PARTS.** Before using this product, carefully check that it will operate properly and perform its intended function. Check for damaged parts and any other conditions that may affect the operation of this product. Replace or repair damaged or worn parts immediately.
11. **REPLACEMENT PARTS AND ACCESSORIES.** When servicing, use only identical replacement parts. Only use accessories intended for use with this product. Approved accessories are available from Harbor Freight Tools.
12. **MAINTAIN THIS PRODUCT WITH CARE.** Keep this tool clean and dry, and keep saw blades clean and sharp for better and safer performance.
13. **MAINTENANCE:** For your safety, service and maintenance should be performed regularly by a qualified technician.
14. **USE THE RIGHT PRODUCT FOR THE RIGHT JOB.** There are certain applications for which this product was designed. Do not use small equipment, tools or attachments to do the work of larger industrial equipment, tools or attachments. Do not use this product for a purpose for which it was not intended.

## SPECIFIC PRODUCT WARNINGS AND PRECAUTIONS

1. **GROUND THIS PRODUCT.** The electrical power cord for this product is equipped with a grounded 3-prong plug. Never remove the grounding prong or modify the plug in any way. Do not use adapter plugs with this product. When in use, make sure this product is always plugged into a grounded 3-hole electrical receptacle with an appropriate breaker switch in-line.
2. **MAKE SURE THE POWER SWITCH IS IN THE “OFF” POSITION BEFORE PLUGGING IN THE POWER CORD.**
3. **DO NOT ABUSE THE POWER CORD.** Do not use the cord to pull the 3-prong plug from a power outlet. Keep cord away from heat, oil, sharp edges, and moving parts. Replace damaged cord immediately. Route the power cord safely. Protect it from being damaged by other equipment in the shop. Do not route the cord where it can be walked on or tripped over.
4. **IF YOU USE AN EXTENSION CORD, MAKE SURE TO USE ONLY UL APPROVED CORDS HAVING THE CORRECT GAUGE AND LENGTH. (SEE FIGURE A.)**

**Figure A**

Nameplate Amperes	Extension Cord Length					
	25'	50'	75'	100'	150'	200'
0-5	16	16	16	14	12	12
5.1 - 8	16	16	14	12	10	-
8.1 - 12	14	14	12	10	-	-
12.1 - 15	12	12	10	10	-	-
15.1 -20	10	10	10	-	-	-

5. **MAINTAIN A SAFE WORK ENVIRONMENT.** Do not use this product in or near damp or wet areas. Do not expose this product to rain. Keep work area well lit. Make sure there is adequate surrounding work space. Use this product in a well ventilated area. Do not operate this product in the presence of flammable liquids, gases, or dust. To avoid accidental electric shock, do not let your body come in contact with grounded surfaces such as pipes, radiators, ranges and refrigerators.
6. **DO NOT FORCE THE EQUIPMENT.** This Jointer will do the work better and safer at the speed and capacity for which it was designed.
7. **KEEP ALL GUARDS IN PLACE AND IN WORKING ORDER.**
8. **REMOVE ALL ADJUSTING WRENCHES FROM THE JOINTER BEFORE TURNING IT ON.**

9. **AVOID UNINTENTIONAL STARTING.** Make sure you are prepared to begin work before turning the START switch on.
10. **DO NOT USE THIS TOOL FOR CUTTING METALS OR BRITTLE MATERIALS.** Do not cut dangerous materials, such as asbestos which can cause harmful dust or vapors.
11. **ALLOW THE CUTTER HEAD (PART #8B) TO SPIN UP TO FULL SPEED BEFORE FEEDING WOOD INTO IT.** When turning it off, allow the Cutter Head to spin down and stop on its own. Do not press against the Cutter Head to stop it.
12. **DO NOT FORCE THE MATERIAL INTO THE CUTTER HEAD WHEN CUTTING.** Apply moderate pressure, allowing the Cutter Head to cut without being forced.
13. **NEVER ATTEMPT TO REMOVE MATERIAL STUCK IN THE MOVING PARTS OF THE JOINTER WHILE IT IS PLUGGED IN AND RUNNING.**
14. **TURN OFF THE JOINTER IF THE WOODSTOCK IS TO BE BACKED OUT OF AN UNCOMPLETED CUT.**
15. **ALWAYS KEEP HANDS AND FINGERS AWAY FROM THE CUTTER HEAD.** Use a Push Block (not provided) and the Cutter Head Guard (part #42B) at all times.
16. **MAKE SURE THE WORKPIECE IS FREE FROM NAILS AND ANY OTHER FOREIGN OBJECT WHICH COULD DAMAGE THE CUTTER HEAD.**
17. **USE MATERIAL THAT IS AT LEAST 8" LONG, MORE THAN 3/4" WIDE, AND MORE THAN 1/4" THICK.**
18. **DO NOT MAKE CUTS DEEPER THAN 1/8" IN A SINGLE PASS.** If the cut is more than 1-1/2" wide, set the depth of the cut to 1/16" to avoid overloading the Jointer and reduce the possibility of the workpiece kicking back.
19. **ALWAYS FEED THE WORKPIECE INTO THE CUTTER HEAD AND AGAINST ITS ROTATION.**
20. **MAKE SURE THE WORKPIECE IS SUPPORTED AT ALL TIMES DURING OPERATION.** Use a Roller Stand (not provided) with larger workpieces, if necessary.
21. **MAINTAIN CONTROL OF THE WORKPIECE AT ALL TIMES.** Never allow the workpiece to rest on the moving Cutter Head without holding on to it.

22. **BEFORE TRYING NEW OR COMPLICATED TECHNIQUES, STUDY THE PROCEDURE, USE HOLD-DOWN AND PUSH BLOCKS, JIGS, OR STOPS. PRACTICE WITH SCRAP WOOD.**
23. **ALWAYS DISCONNECT THE JOINTER FROM ITS ELECTRICAL SUPPLY SOURCE BEFORE PERFORMING ANY SERVICES OR MAINTENANCE** such as leaving the work area, moving the tool from one location to another, cleaning sawdust from the unit, etcetera.
24. **CAUTION:** Some woods contain preservatives such as copper chromium arsenate (CCA) which can be toxic. When cutting these materials extra care should be taken to avoid inhalation and minimize skin contact.
25. **WARNING:** This product contains or produces a chemical known to the State of California to cause cancer and birth defects (or other reproductive harm). (*California Health & Safety Code 25249.5 et seq.*)

## UNPACKING

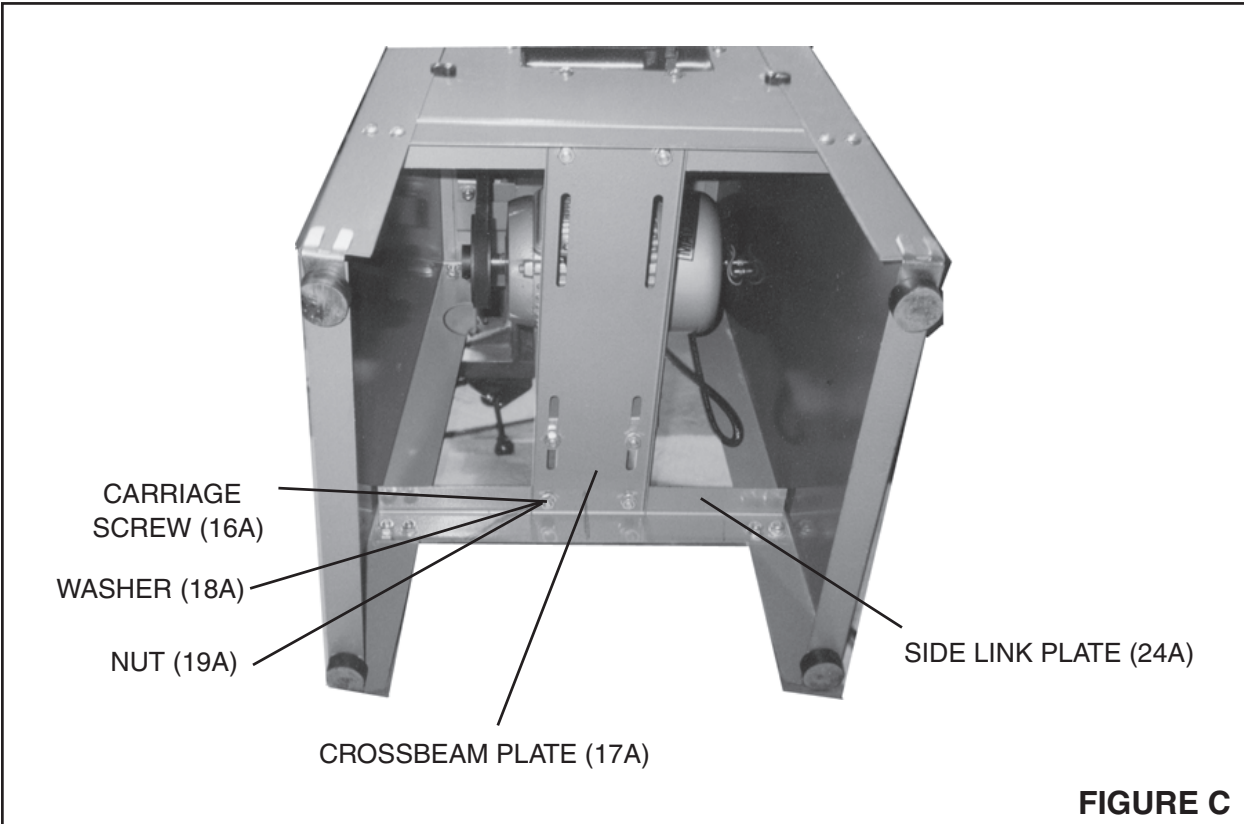
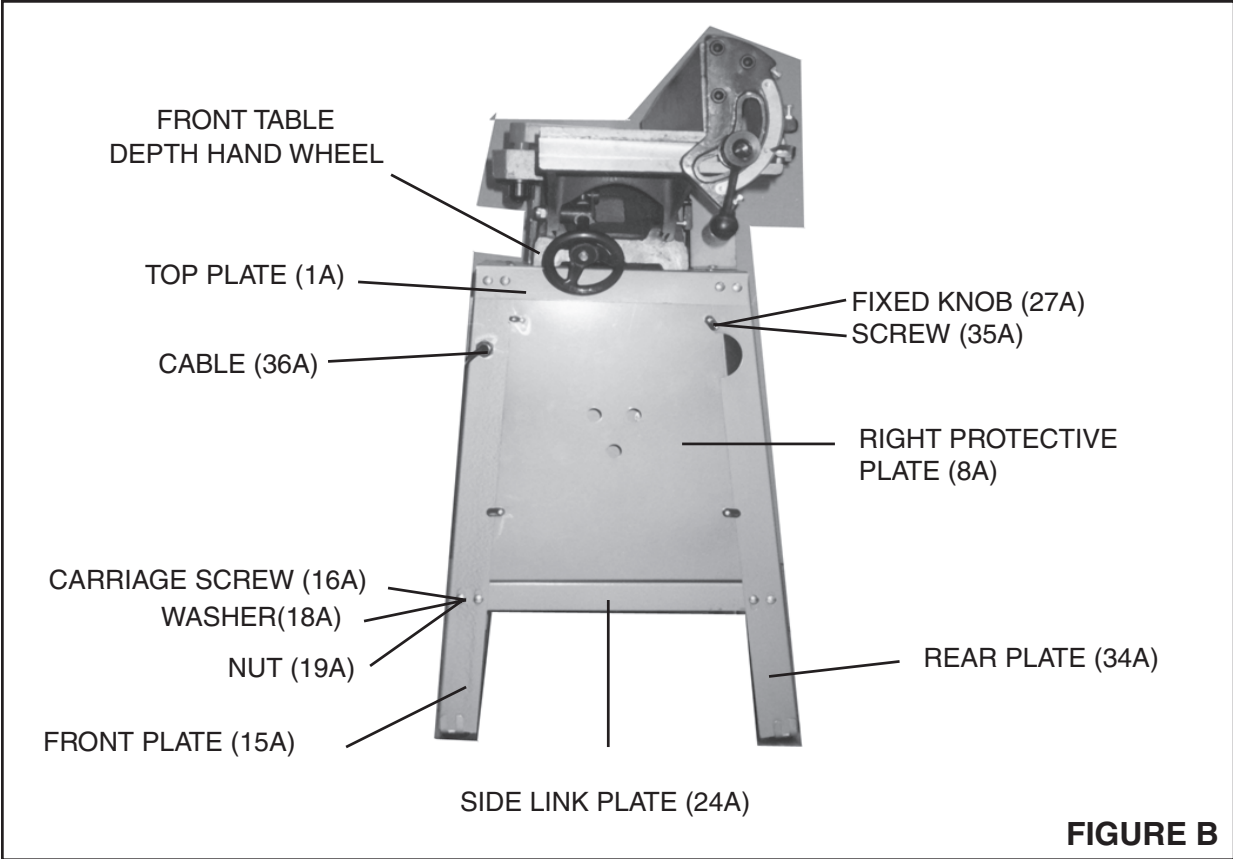
When unpacking, check to make sure all parts shown on the Parts Lists (pages 22 and 24) are included. If any parts are missing or broken, please call Harbor Freight Tools at the number shown on the cover of this manual as soon as possible.

## ASSEMBLY INSTRUCTIONS

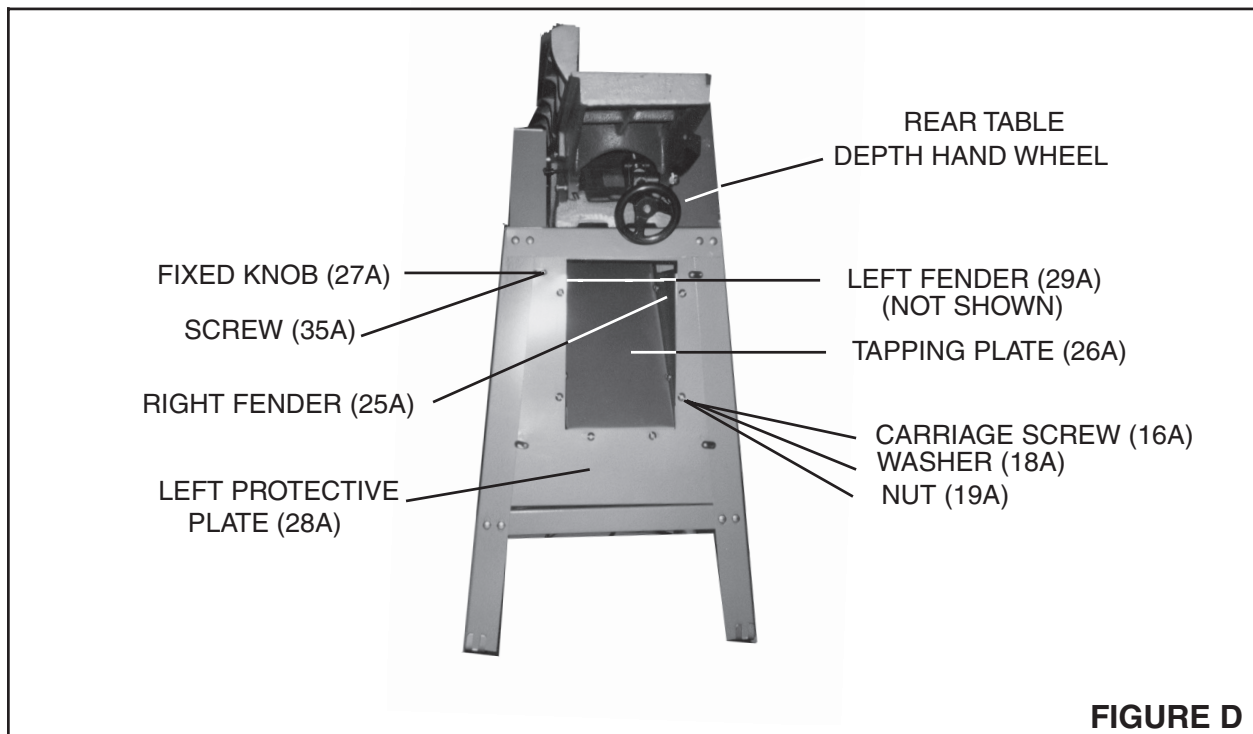
**NOTE: For additional references to the parts listed below, refer to the Assembly and Wiring Diagrams on pages 23, 25, and 26 of this manual.**

### **TO ASSEMBLE THE STAND:**

1. **NOTE:** During the following steps, *loosely finger tighten* all Carriage Screws (part #16A) and Nuts (part #19A).
2. Locate the Front Plate (part #15A) and the Rear Plate (part #34A). Also, locate the two Side Link Plates (part #24A). **(See Figures B, C, and Assy. Diagram A.)**



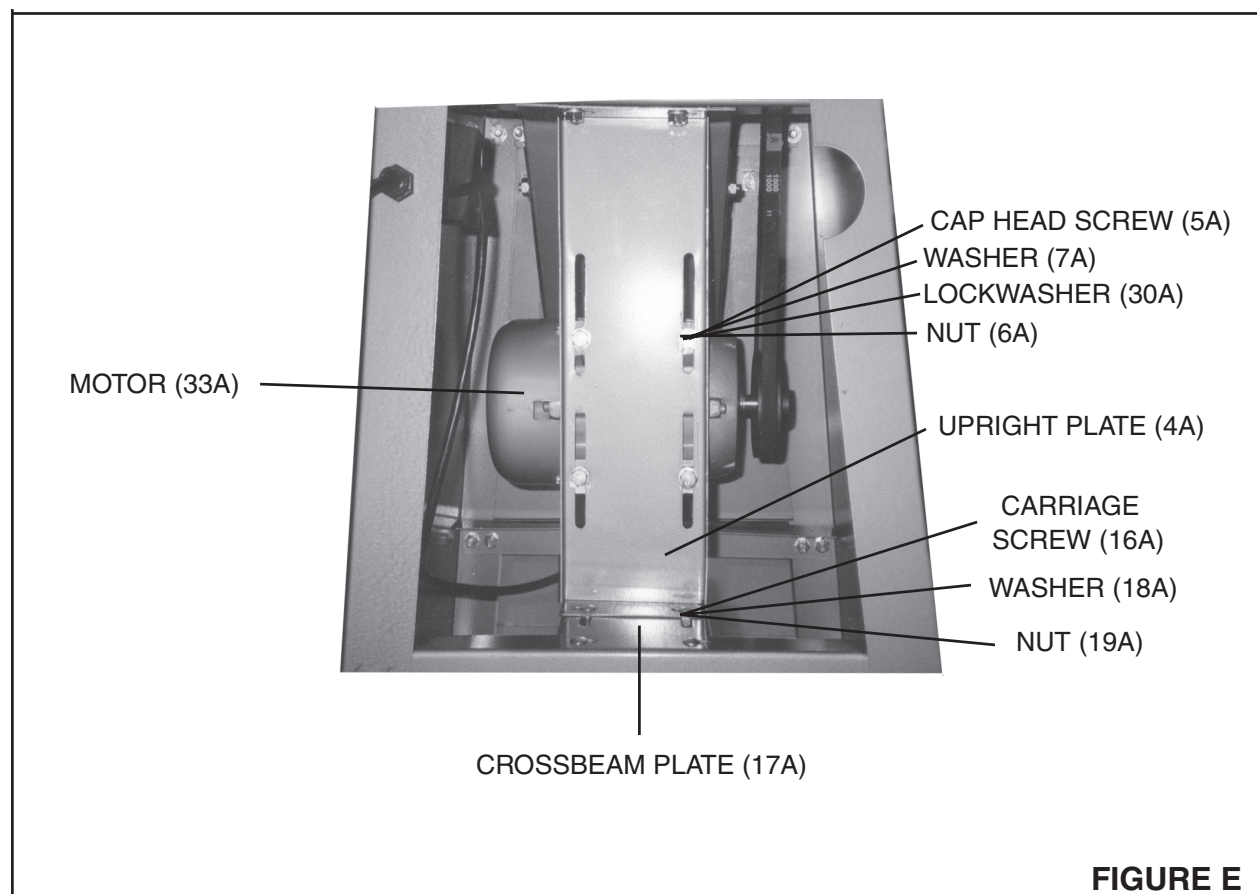
3. Insert eight Carriage Screws (part #16A) from the outside of the eight lower holes in the Front Plate (part #15A), Rear Plate (part #34A), and through the two side holes located at each end of the Side Link Plates (part #24A).
4. Use eight Washers (part #18A) and eight Nuts (part #19A) to secure the Front Plate (part #15A), Rear Plate (part #34A), and the Side Link Plates (part #24A).
5. Locate the Crossbeam Plate (part #17A). Connect the Crossbeam Plate to the underside of the two Side Link Plates (part #24A) by inserting four Carriage Screws (part #16A) from the two top holes of each Side Link Plate downward through the two holes at each end of the Crossbeam Plate.
6. Secure the Crossbeam Plate (part #17A) to the two Side Link Plates (part #24A), using four Washers (part #18A) and four Nuts (part #19A).
7. Make sure the Front Plate (part #15A) and the Rear Plate (part #34A) are setting level on the floor. Then, wrench tighten all Carriage Screws (part #16A) and Nuts (part #19A).
8. Locate the Upright Plate (part #4A) and the Upper Link Plate (part #2A).
9. The Jointer Stand features a Dust Chute. To assemble the Dust Chute, locate the Tapping Plate (part #26A), the Right Fender (part #25A), the Left Fender (part #29A), and the Left Protective Plate (part #28A). **(See Figure D and Assy. Diagram A.)**



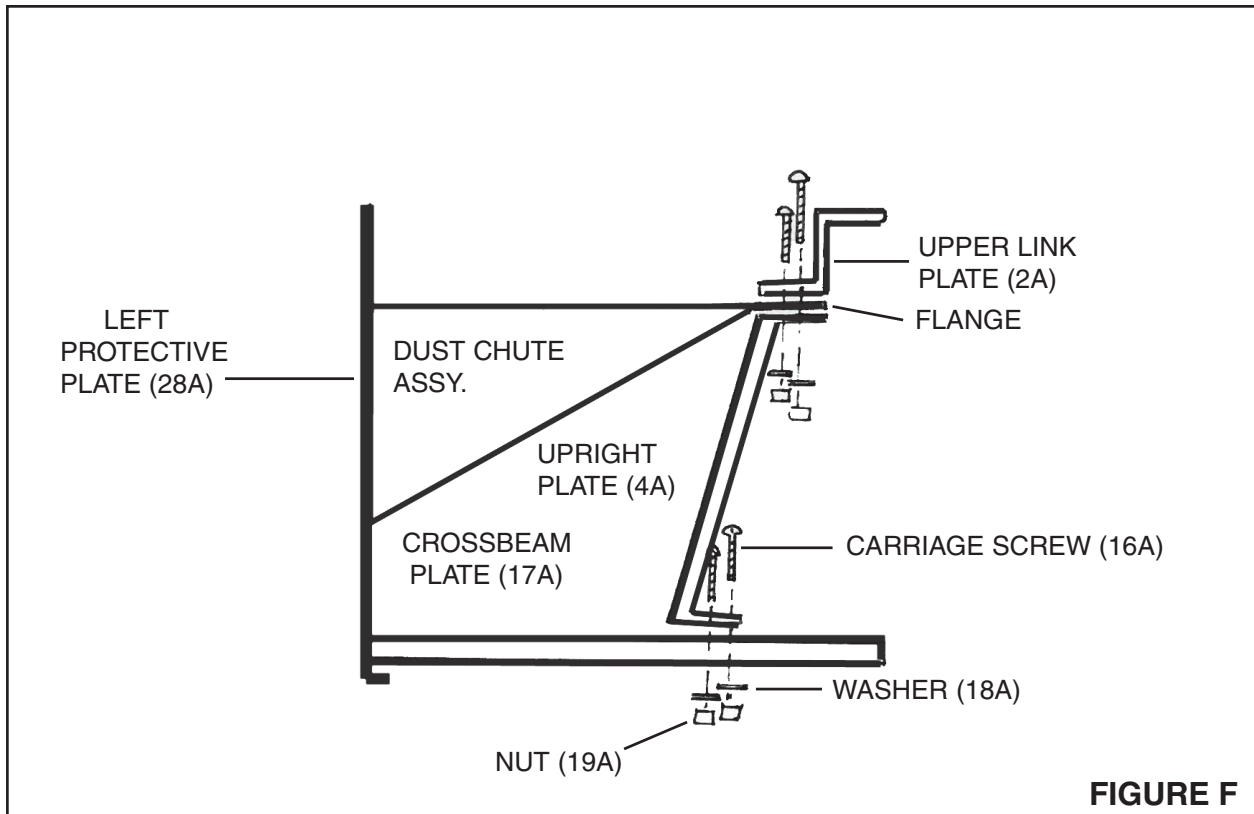
**FIGURE D**



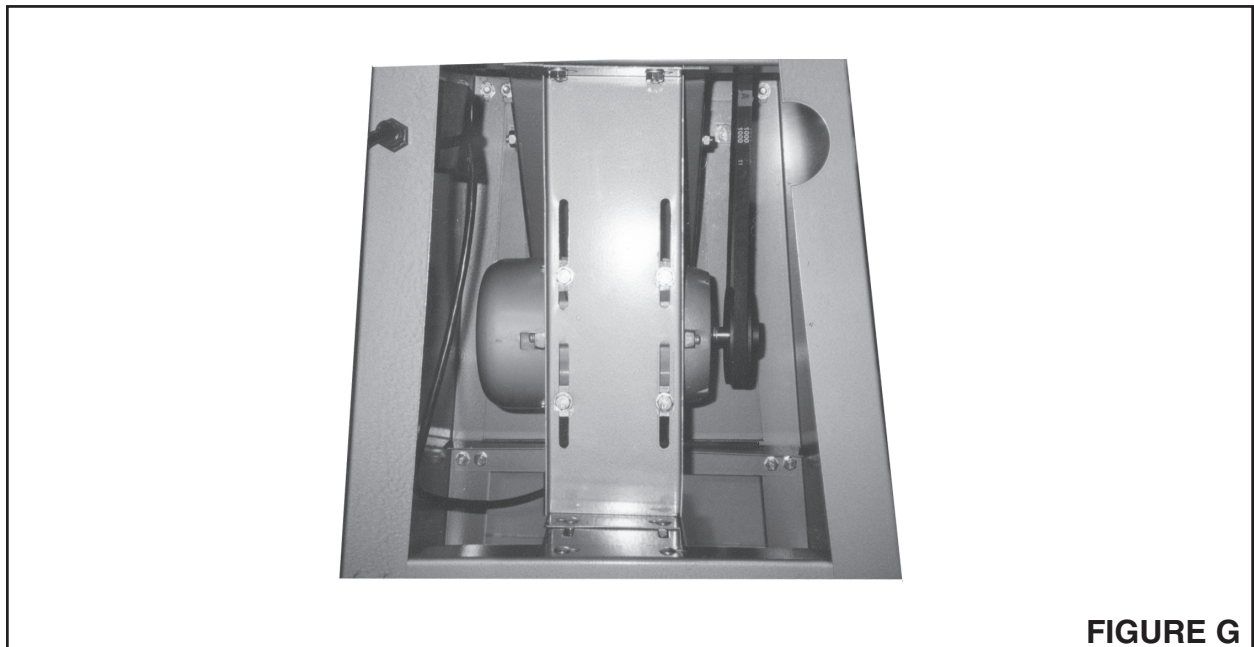
10. Attach the Right Fender (part #25A), with its wide end at the top, to the right side of the Tapping Plate (part #26A), using two Carriage Screws (part #16A), two Washers (part #18A), and two Nuts (part #19A). NOTE: The flanges on the Tapping Plate should be facing outward as shown in Assembly Diagram A.
11. Attach the Left Fender (part #29A), with its wide end at the top, to the left side of the Tapping Plate (part #26A), using two Carriage Screws (part #16A), two Washers (part #18A), and two Nuts (part #19A).
12. Then, attach the Left Protective Plate (part #28A) to the Right Fender (part #25A) and Left Fender (part #29A), using four Carriage Screws (part #16A), four Washers (part #18A), and four Nuts (part #19A).
13. Set the assembled *Dust Chute* aside until after the Motor (part #33A) has been connected to the unit.
14. Connect the bottom of the Upright Plate (part #4A) to the Crossbeam Plate (part #17A), using two Carriage Screws (part #16A), two Washers (part #18A), and two Nuts (part #19A). (See Figures E, F, and Assy. Diagram A.)



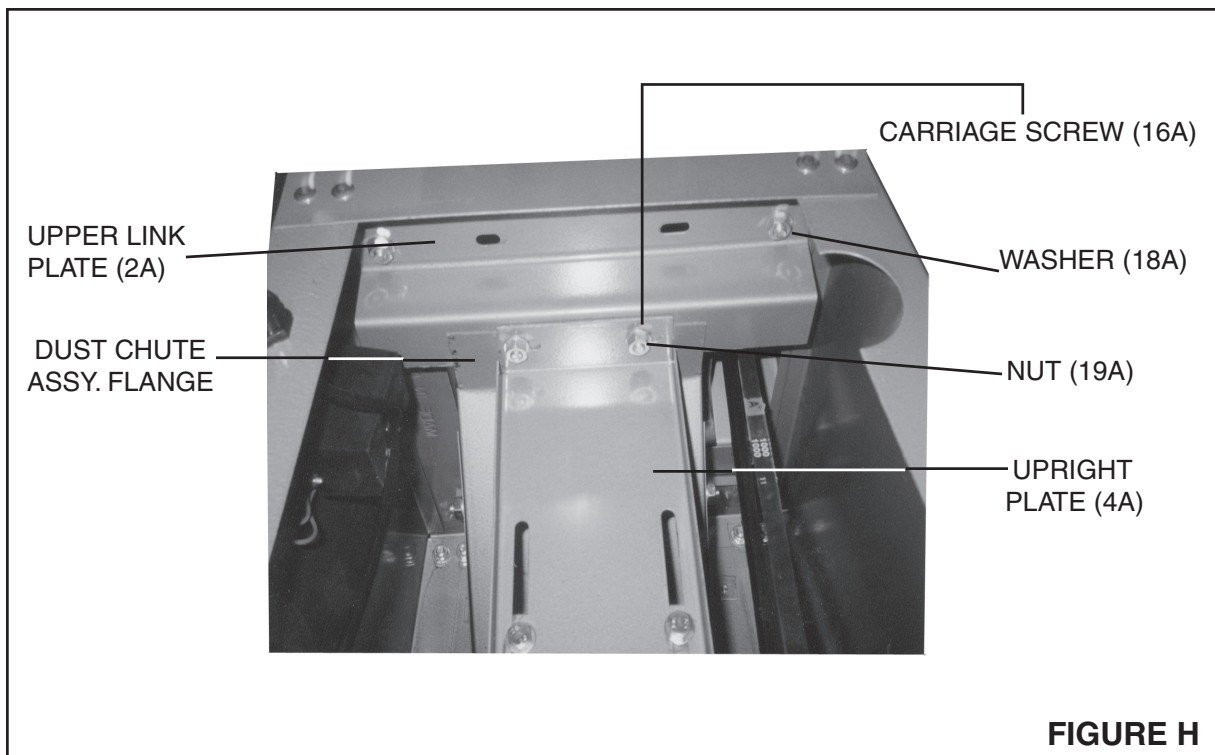
**FIGURE E**



- The Motor (part #33A), fastens to the Upright Plate (part #4A). Insert four Cap Head Screws (part #5A) through the bracket on the Motor, and then through the Upright Plate. Temporarily, *loosely* secure the Motor to the Upright Plate, using four Washers (part #7A), four Lock Washers (part #30A), and four Nuts (part #6A). (See Figure G, and Assy. Diagram A.)

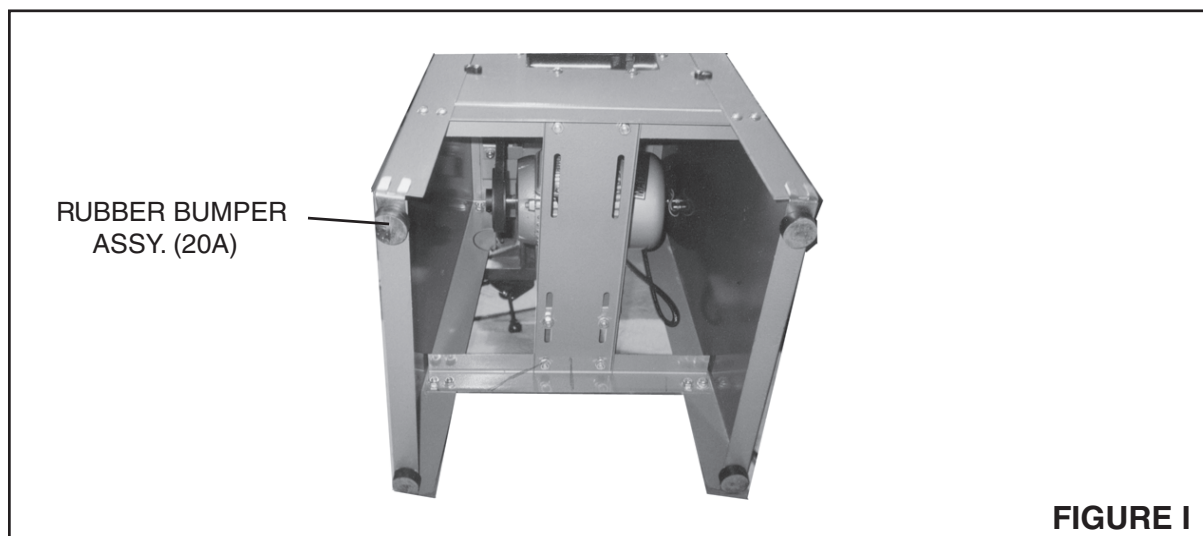


16. To connect the Motor's Electrical Cord to the Switch (part #14A), and to connect the Cable (part #36A) to the Switch, **refer to the Wiring Diagram, page 26.**
17. To attach the Switch (part #14A), insert the Switch in the rectangular hole located on the upper/right corner of the Front Plate (part #15A). Secure the Switch to the Front Plate, using two Machine Screws (part #11A), two Washers (part #12A), and two Nuts (part #13A). **(See Figure J, Wiring Diagram, and Assy. Diagram A.)**
18. Retrieve the previously assembled *Dust Chute* assembly with its attached Left Protective Plate (part #28A). Also, locate the Upper Link Plate (part #2A).
19. Position the Dust Chute assembly so that its upper flange rests on top of the upper flange of the Upright Plate (part #4A). Then, position the Upper Link Plate (part #2A) on top of the Dust Chute assembly flange. Connect the Upper Link Plate, Dust Chute assembly flange, and Upright Plate together, using two Carriage Screws (part #16A), two Washers (part #18A), and two Nuts (part #19A). **(See Figures F, H, and Assy. Diagram A.)**



20. Locate the Right Protective Plate (part #8A) and secure it to the right side of the body of the Stand, using four Fixed Knobs (part #27A) and four Screws (part #35A). **(See Figure B, and Assy. Diagram A.)**

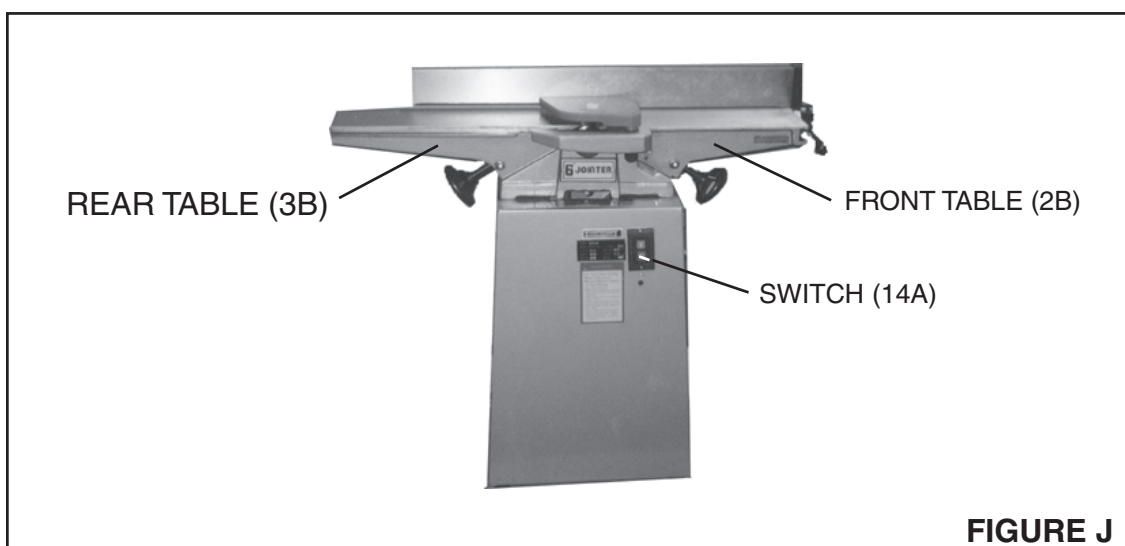
21. Locate the Top Plate (part #1A) and attach it to the Upper Link Plate (part #2A) on the right side of the Stand. Insert two Carriage Screws (part #16A) downward through the holes (located at the right/front and right/rear) of the Top Plate and through the holes located at each end of the Upper Link Plate. Secure the Carriage Screws with two Washers (part #18A) and two Nuts (part #19A). **(See Figure B, and Assy. Diagram A.)**
22. Next, insert two Carriage Screws (part #16A) horizontally through the holes (located at each corner) of the Top Plate (part #1A) and through the holes located at both upper sides of the Front Plate (part #15A) and both upper sides of the Rear Plate (part #34A). Secure the Carriage Screws with eight Washers (part #18A) and eight Nuts (part #19A). **(See Figure B, and Assy. Diagram A.)**
23. With assistance, turn the Stand upside down, and attach the Rubber Bumper (part #20A) assemblies to each of the four corners. **(See Figure I, and Assy. Diagram A.)**



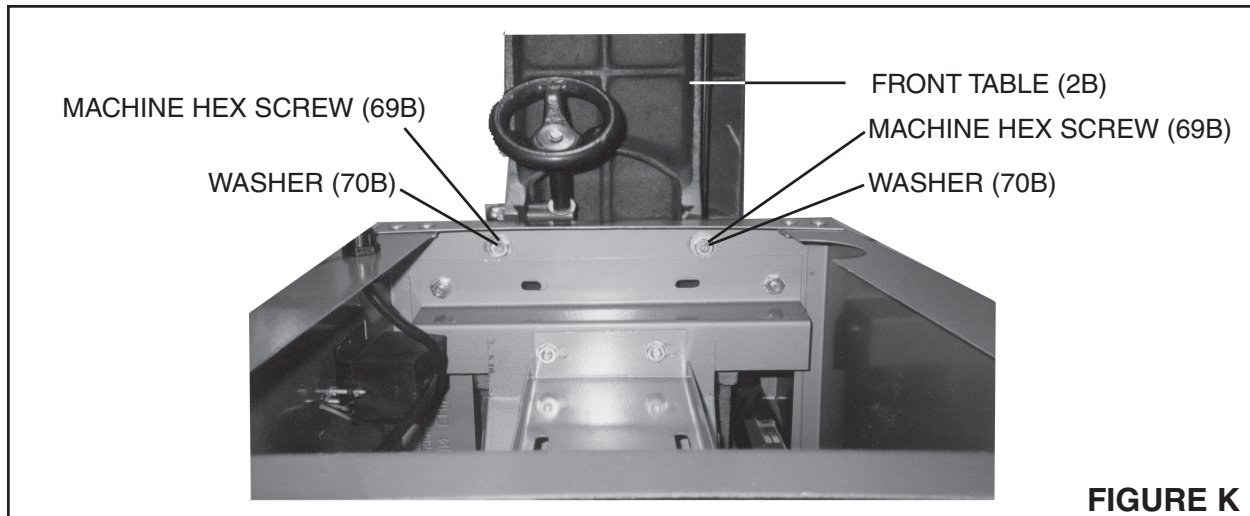
24. With assistance, set the Stand upright. Check to make sure the Stand is setting square on the floor. Then, **wrench tighten all Screws (part #5A), Carriage Screws (part #16A), and Nuts (parts #6A, 19A) throughout the Stand securely.**
25. Secure the Left Protective Plate (part #28A) to the left side of the body of the Stand, using four Fixed Knobs (part #27A) and four Screws (part #35A). **(See Figure D, and Assy. Diagram A.)**

## TO ASSEMBLE THE JOINTER TO THE STAND:

1. Open the panel on the Left Protective Plate (part #28A), and temporarily set it aside. **(See Figure D, and Assy. Diagram A.)**
2. Locate the Front Table (part #2B) and Rear Table (part #3B). **(See Figure J, and Assy. Diagram B.)**
3. With assistance, place the Front Table (part #2B) and Rear Table (part #3B) on the Top Plate (part #1A).
4. On the underside of the Front Table (part #2B) there are *two* threaded mounting holes. Position the Front Table so that its two threaded mounting holes align with the holes located on the Top Plate (part #1A) at its edge. **(See Figure K, and Assy. Diagram A.)**
5. Secure the Front Table (part #2B) to the Top Plate (part #1A) by inserting upward two Machine Hex Screws (part #69B), with two Washers (part #70B) into the two threaded mounting holes of the Front Table. NOTE: Be sure to *wrench tighten* the Machine Hex Screws.
6. On the underside of the Rear Table (part #3B) is *one* threaded mounting hole. Position the Rear Table so that the threaded mounting hole aligns with the hole located on the Top Plate (part #1A) at its edge. **(See Figure L, and Assy. Diagram A.)**
7. Secure the Rear Table (part #3B) to the Top Plate (part #1A) by inserting upward one Machine Hex Screw (part #69B), with one Washer (part #70B) into the threaded mounting hole of the Rear Table. NOTE: Be sure to *wrench tighten* the Machine Hex Screw.

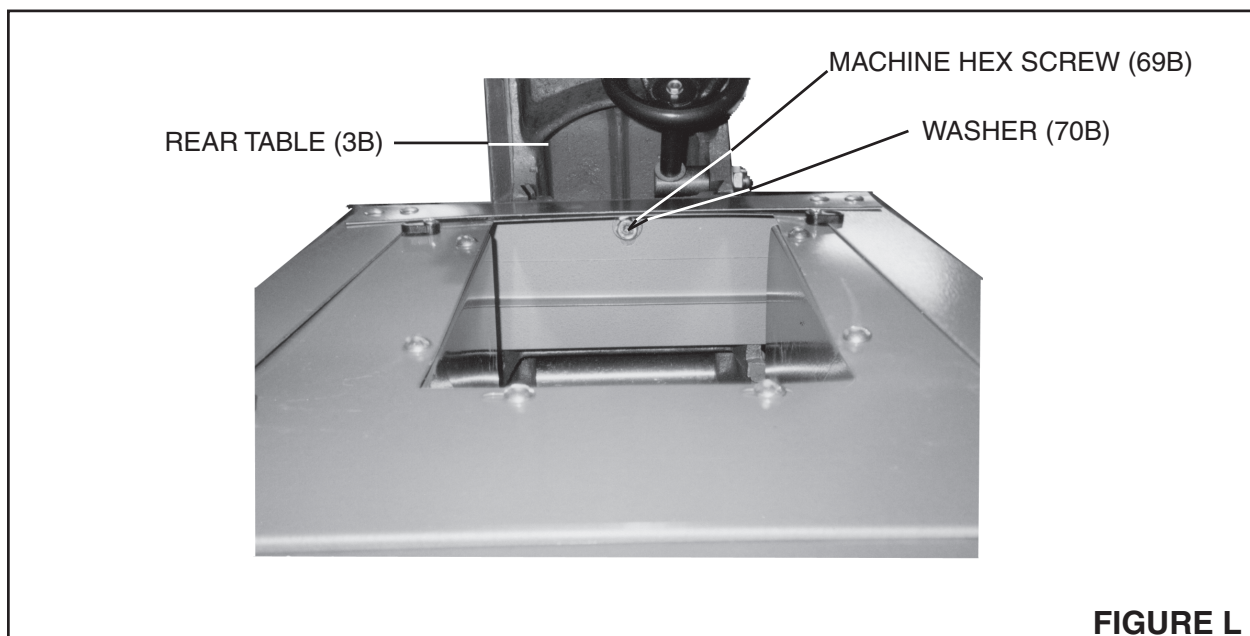




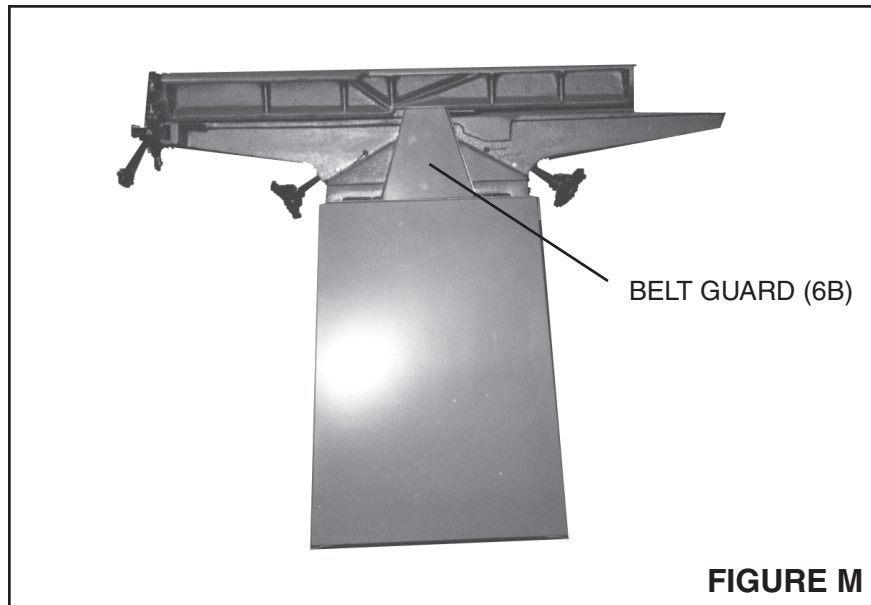


**FIGURE K**

8. Slightly loosen the four Cap Head Screws (part #5A) that hold the Motor (part #33A) onto the Upright Plate (part #4A). **(See Figure G, Assy. and Diagram A.)**
9. Place the Belt (part #12B) on the Motor's Belt Pulley (part #32A). Then, slide the Motor (part #33A) upward and pull the Belt up and over the Cutter Head's Pulley (part #11B). **(See Figure G, and Assy. Diagrams A and B.)**
10. Slide the Motor (part #33A) downward until the tension on the Belt (part #12B) feels snug. Then, retighten all four Cap Head Screws (part #5A) that hold the Motor onto the Upright Plate (part #4A).
11. Close the panel on the Left Protective Plate (part #28A). **(See Figure D, and Assy. Diagram.)**
12. Attach the Belt Guard (part #6B) to the rear of the Top Plate (part #1A), using two Pan Head Slotted Machine Screws (part #66B), two Washers (part #67B), and two Nuts (part #68B). **(See Figure M, and Assy. Diagram B.)**



**FIGURE L**



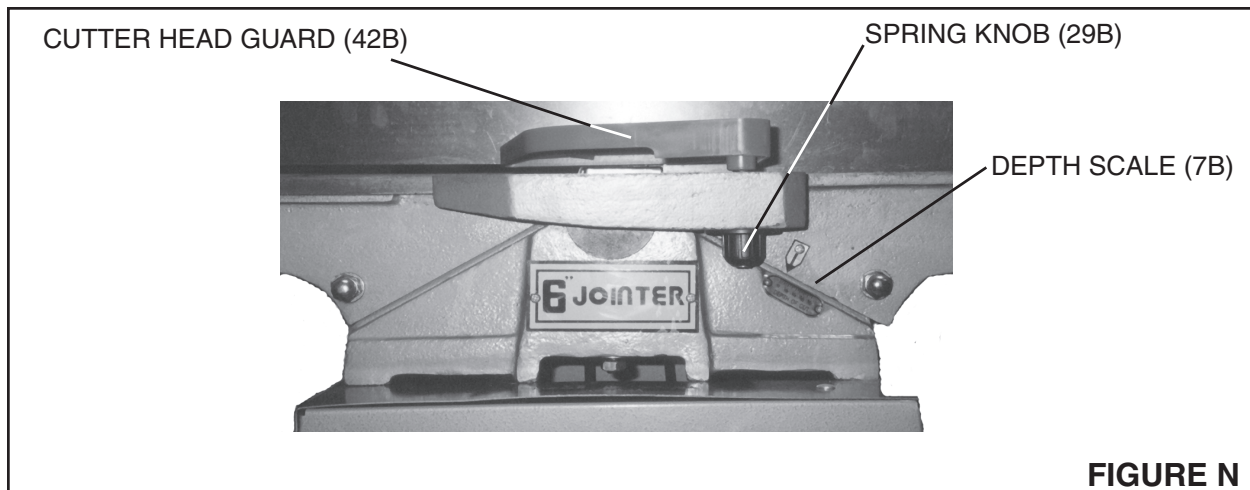
**WARNING: CHECK BLADE SETTING AND TIGHTNESS BEFORE INITIAL USE.**

### **OPERATING INSTRUCTIONS**

**NOTE:** For additional references to the parts listed below, refer to the Assembly and Wiring Diagrams on pages 22, 24, and 26 of this manual. **Note: The electrical cord must always be unplugged during assembly and while making adjustments to the Jointer.**

#### **TO RAISE AND LOWER THE FRONT AND REAR TABLES:**

1. To raise or lower the Front Table (part #2B), use the Depth Hand Wheel located under the Front Table. **NOTE:** For greater accuracy, use the Depth Scale (part #7B). (See Figure B, Figure N, and Assy. Diagram B.)
2. To raise or lower the Rear Table (part #3B), use the Depth Hand Wheel located under the Rear Table. (See Figure D, and Assy. Diagram B.)



REV 12/06

3. After setting the cutting depth for the Front Table (part #2B), set the depth for the Rear Table (part #3B) between 1/16" and 1/32" higher than the Front Table.  
NOTE: This is necessary so that the workpiece is supported on both Tables. If the Rear Table is too high, it will raise the workpiece and the cutting depth will be too shallow. If the Rear Table is too low, the workpiece will tilt down to it and the cut into the workpiece will be too great.
4. Two Gibs (part #5B) are provided and were pre-adjusted by the manufacturer. Both are inserted under the Front Table (part #2B) and Rear Table (part #3B) into grooves between the Tables and Base (part #1B). The Gibs act as shims, and take up any free play between the Tables and the Base. **(See Assy. Diagram B.)**
5. *If further adjustments to the Rear Table's Gib (part #5B) is needed, loosen the Lock Screw (part #37B) which is located at the back of the Rear Table (Part #3B). Then, loosen the three Gib Adjusting Screws (part #35B) which are located next to the Lock Screw. (See Assy. Diagram B.)*
6. Starting first with the lowest Adjusting Screw (part #35B), work upward and retighten all three Adjusting Screws. NOTE: As you proceed toward the top Adjusting Screw, raise up gently on the outer edge of the Rear Table (part #3B). This will offset any tendency of the Table casting to droop or sag and permit the Gib (part #5B) to be raised to a more proper fit.
7. When all three Gib Adjusting Screws (part #35B) have been retightened, make sure to retighten the Lock Screw (part #37B).
8. *Adjustments to the Front Table's Gib (part #5B) are performed in the same manner as mentioned above.*

#### **TO ASSEMBLE THE CUTTER HEAD GUARD:**

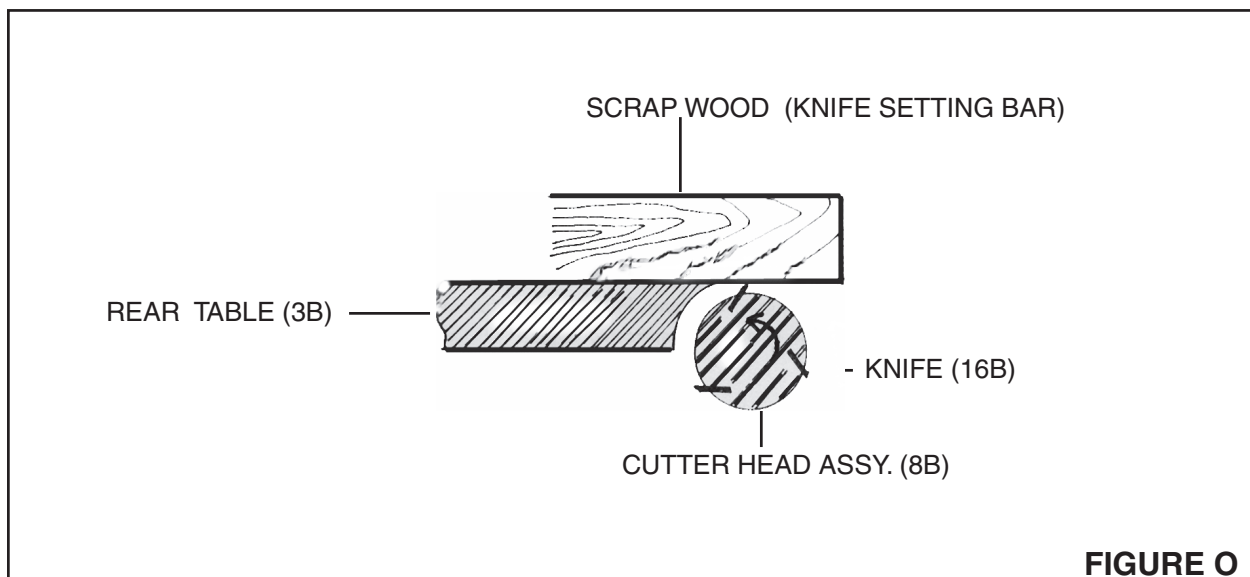
1. To attach the Cutter Head Guard (part #42B) to the Jointer, insert the assembly down through the hole in the Front Table (part #2B). **(See Figure N, and Assy. Diagram B.)**
2. A Torsion Spring (part #28B) is provided in the Spring Knob (part #29B) that returns the Cutter Head Guard (part #42B) over the Cutter Head Assembly (part #8B) after a cut has been made.
3. Turn the Spring Knob (part #29B) to put tension on the Torsion Spring (part #28B) before inserting the post down through the hole in the Front Table (part #2B).  
NOTE: Make sure the Spring in the Spring Knob engages the slot located at the end of the post.



4. If the spring tension is too much, or not enough, remove the Cutter Head Guard (part #42B) and adjust the spring tension accordingly by rotating the Spring Knob (part #29B).

### **TO ADJUST THE CUTTER HEAD ASSEMBLY:**

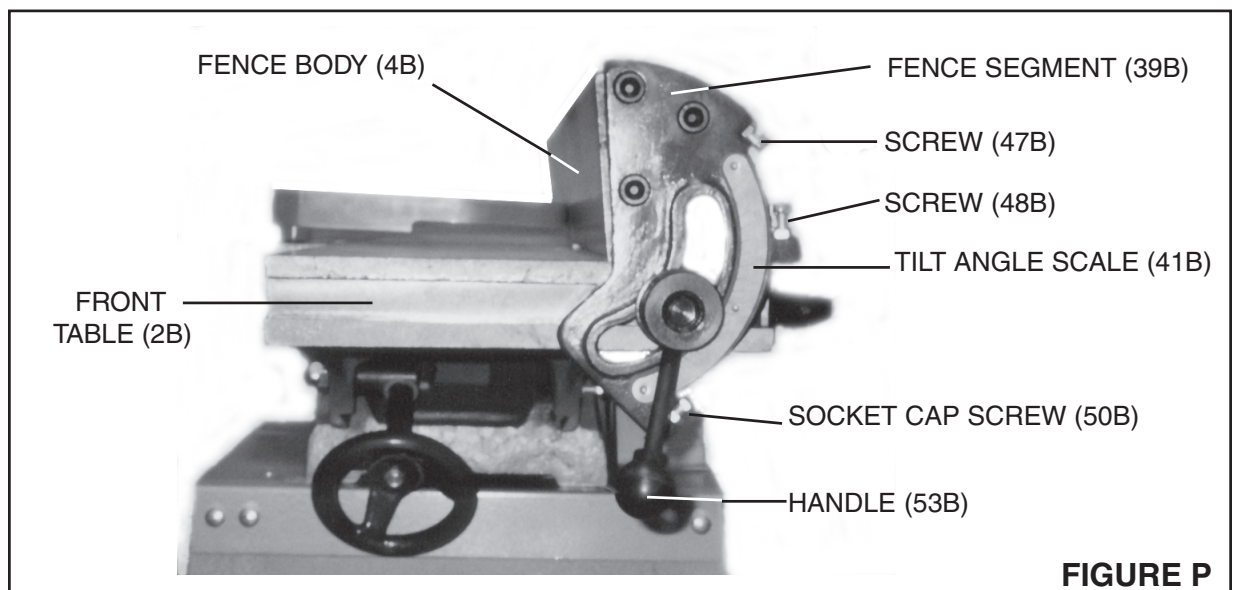
1. The three Knives (part #16B) on the Cutter Head Assembly (part #8B) must always be kept sharp for proper performance. Should the Knives need to be sharpened or replaced, follow the below listed steps.
2. DISCONNECT THE JOINTER FROM ITS ELECTRICAL POWER SOURCE.
3. Place a Knife (part #16B) in its groove in the Cutter Head Assembly (part #8B) so that the rear edge of the bevel is 1/16" from the surface of the Cutter Head. **(See Assy. Diagram B.)**
4. Slide the Knife Stock Bar (part #14B) into place and lightly tighten the Knife Set Screws (part #17B).
5. Place a "Knife Setting Bar" made of a piece of flat scrap piece of wood, approximately 12" long, on the Rear Table (part #3B). **(See Figure O.)**
6. Open the panel on the Left Protective Plate (part #28A). **(See Figure D, and Assy. Diagram A.)**
7. Use the Pulley Belt (part #12B) to rotate the Cutter Head Assembly (part #8B) *backward*. **Caution:** Do not attempt to turn the Cutter Head Assembly by placing your hand on it.



8. While slowly rotating the Cutter Head Assembly backward, adjust the Knife (part #16B) until it just touches the scrap piece of wood.
9. Using the scrap piece of wood as a guide, check to make sure the Knife (part #16B) at each end is parallel to the top of the Rear Table (part #3B).
10. Repeat the above Steps for the remaining two Knives (part #16B).
11. Close the panel on the Left Protective Plate (part #28A). **(See Figure D, and Assy. Diagram A.)**

**TO ADJUST THE FENCE:**

1. The Fence Body (part #4B) can be moved across the Front Table (part #2B) and Rear Table (part #3B), and tilted 45 degrees right or left at any position on the Tables by means of the Handle (part #53B). **(See Figure P, and Assy. Diagram B.)**
2. To move the Fence Body (part #4B) across the Front Table (part #2B) and Rear Table (part #3B), loosen the Screw (part #48B). Move the Fence Body to the desired location. Then, retighten the Screw.
3. To tilt the Fence Body (part #4B), loosen the Socket Cap Screw (part #50B). Use the Handle (part #53B) to tilt the Fence Body to the desired angle. Then, re-tighten the Socket Cap Screw. **NOTE:** When tilting the Fence Body past the Fixed Plate (part #43B), the Stop Block (part #44B) must be moved out of the way.



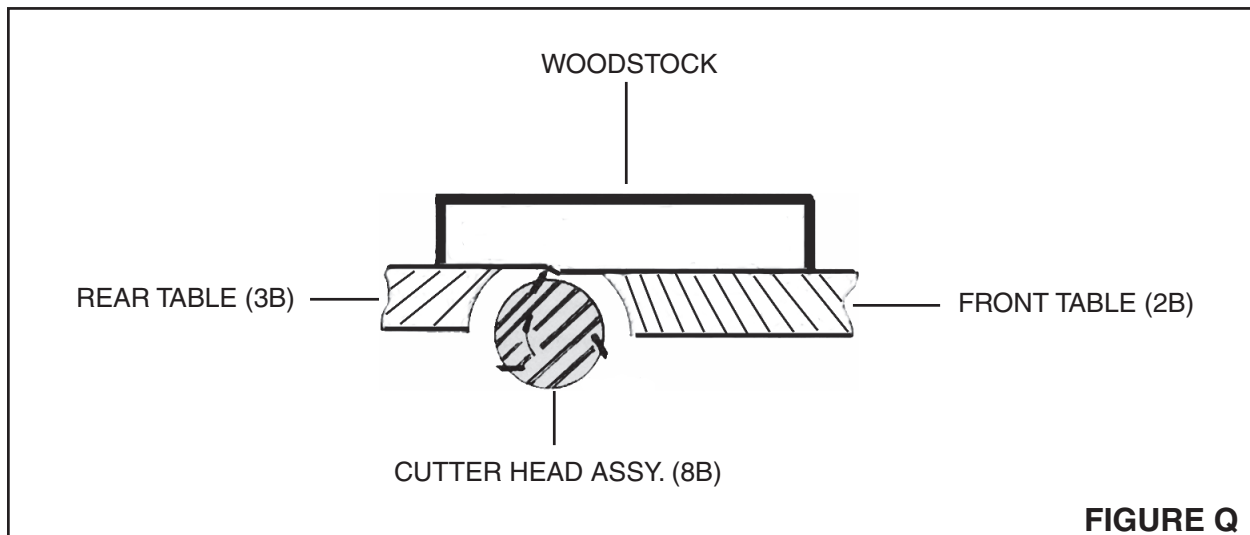
**FIGURE P**

4. The Fence Segment (part #39B) features positive stops at the most used fence positions of 90 degrees and 45 degrees, right and left. Check the Fence Body (part #4B) with a square to make sure the fence is 90 degrees to the Front Table (part #2B) and Rear Table (part #3B). *If an adjustment is necessary*, loosen the Screw (part #47B). Turn the Screw in or out against the Stop Block (part #44B) until the Fence Body is at 90 degrees to the Front Table and Rear Table. Then, retighten the Screw. Follow this same procedure to check the positive stops at 45 degrees, right and left.

## **GENERAL CUTTING PROCEDURES:**

### **Placement Of Hands During The Cutting Process**

1. **Caution:** Never pass hands directly over the Cutter Head Assembly (part #8B) when cutting the workpiece.
2. At the start of the cut, the left hand holds the workpiece firmly against the Front Table (part #2B) and the Fence Body (part #4B), while the right hand pushes the workpiece toward the Cutter Head Assembly (part #8B).
3. After the cut is under way, the new surface of the workpiece rests firmly on the Rear Table (part #3B). The right hand pushes the workpiece forward, but before the right hand reaches the Cutter Head Assembly (part #8B) it should be moved to the workpiece on the Rear Table. **(See Figure Q, and Assy. Diagram B.)**
4. **NOTE:** Whenever working on *short or thin* workpieces, always use a push block (not provided).



**FIGURE Q**

### **To Joint An Edge:**

1. Set the Fence Body (part #4B) square with the Front Table (part #2B) and Rear Table (part #3B).
2. The depth of cut should be the minimum required to obtain a straight edge.  
NOTE: Hold the best face of the workpiece against the Fence Body (part #4B) throughout the cut.

### **To Joint A Warped Workpiece:**

1. If the workpiece to be jointed is dished or warped, take light cuts until the surface is flat.
2. Avoid excessive pressure on the workpiece. Excessive pressure will spring the workpiece back, and it will remain curved after the cut is completed.

### **To Cut A Bevel:**

1. To cut a bevel, lock the Fence Body (part #4B) at the required angle, and run the workpiece across the Cutter Head Assembly (part #8B) while keeping the workpiece firmly against the Fence Body and the Front Table (part #2B) and Rear Table (part #3B). NOTE: Several passes may be necessary to achieve the desired results.

### **To Cut An Edge To A Taper:**

1. Instead of laying the workpiece on the Front Table (part #2B), lower the forward end of the workpiece onto the Rear Table (part #3B). Do this very carefully, as the workpiece will span the Cutter Head Assembly (part #8B) which will take a "bite" from the workpiece with a tendency to kick-back unless the workpiece is firmly held.
2. Next, push the workpiece forward, as in ordinary jointing. The effect is to plane off all the stock in front of the Cutter Head Assembly (part #8B) to increase depth, leaving a tapered surface.
3. The ridge left by the Cutter Head Assembly (part #8B) when starting the taper may be removed by taking a very light cut according to the regular method for jointing, with the Front Table (part #2B) raised to its usual position.
4. NOTE: Practice is required in this operation. It is recommended to make trial cuts on waste material.

## CLEANING, INSPECTION, AND MAINTENANCE

1. **Caution:** Always disconnect this Jointer from its electrical power supply source before performing any cleaning, inspection, or maintenance.
2. Before each use, inspect the general condition of the Jointer. Inspect switch, power plug and cord assembly, and extension cord (if used) for damage. Check for loose screws, misalignment, binding of moving parts, broken, cracked, or improper mounting of Cutter Head Guard (part #42B), broken parts and any other condition that may affect its safe operation. If abnormal noise or vibration occurs, turn off the Jointer immediately and have the problem corrected before further use. Do not use damaged equipment.
3. Do not introduce water into the electric motor through the motor vents.
4. Do not use solvents to wipe off the Jointer, as damage may result.
5. With a brush or soft cloth, remove all the sawdust from the Jointer.
6. If necessary, wipe with a damp cloth. You may use a mild detergent.
7. Once clean, lubricate all moving parts with a light oil.
8. When not using Jointer for an extended period of time, unplug the electrical cord and keep the Jointer covered with a cloth cover.

## PLEASE READ THE FOLLOWING CAREFULLY

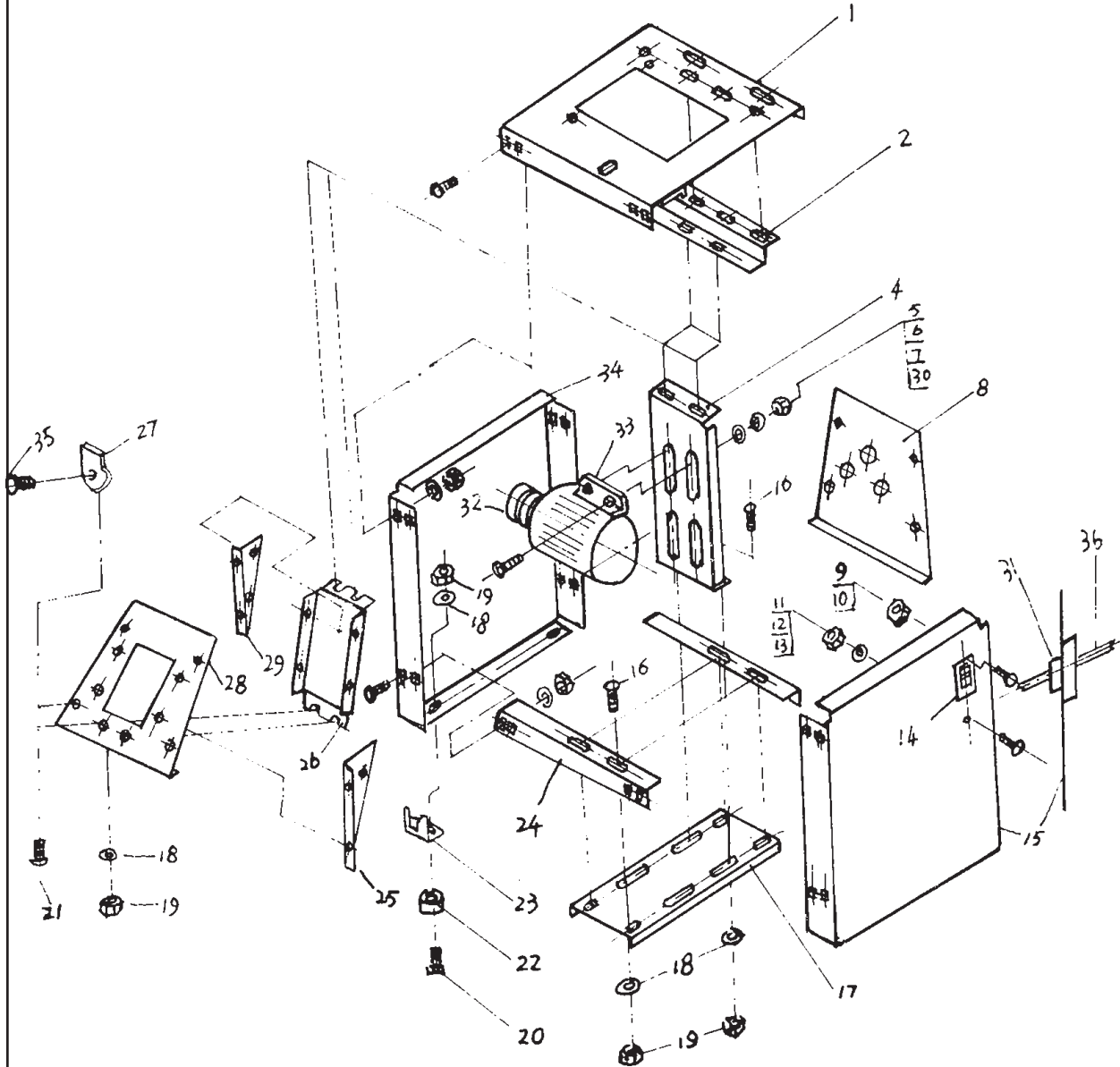
THE MANUFACTURER AND/OR DISTRIBUTOR HAS PROVIDED THE PARTS DIAGRAM IN THIS MANUAL AS A REFERENCE TOOL ONLY. NEITHER THE MANUFACTURER NOR DISTRIBUTOR MAKES ANY REPRESENTATION OR WARRANTY OF ANY KIND TO THE BUYER THAT HE OR SHE IS QUALIFIED TO MAKE ANY REPAIRS TO THE PRODUCT OR THAT HE OR SHE IS QUALIFIED TO REPLACE ANY PARTS OF THE PRODUCT. IN FACT, THE MANUFACTURER AND/OR DISTRIBUTOR EXPRESSLY STATES THAT ALL REPAIRS AND PARTS REPLACEMENTS SHOULD BE UNDERTAKEN BY CERTIFIED AND LICENSED TECHNICIANS AND NOT BY THE BUYER. THE BUYER ASSUMES ALL RISK AND LIABILITY ARISING OUT OF HIS OR HER REPAIRS TO THE ORIGINAL PRODUCT OR REPLACEMENT PARTS THERETO, OR ARISING OUT OF HIS OR HER INSTALLATION OF REPLACEMENT PARTS THERETO.

## PARTS LIST A

Part #	Description	Qty.
1A	Top Plate	1
2A	Upper Link Plate	1
3A	Reinforcing Plate	1
4A	Upright Plate	1
5A	Cap Head Screw (M8 x 25)	4
6A	Nut (M8)	4
7A	Washer	4
8A	Right Protect Plate	1
9A	Nut (M4)	2
10A	Pan Head Phillips Machine Screw (M4 x 8)	2
11A	Pan Head Phillips Machine Screw (M5 x 8)	1
12A	Gear Washer	1
13A	Nut (M5)	1
14A	Switch	1
15A	Front Plate	1
16A	Carriage Screw (M8 x 12)	42
17A	Crossbeam Plate	1
18A	Washer	42
19A	Nut (M8)	42
20A	Rubber Bumper	4
-----	-----	-----
22A	Slotted Carriage Screw	4
23A	Chassis Shim	4
24A	Side Link Plate	2
25A	Right Fender	1
26A	Tapping Plate	1
27A	Fixed Knob	10
28A	Left Protect Plate	1
29A	Left Fender	1
30A	Lock Washer	4
31A	Nut (M8)	4
32A	Belt Pulley	1
33A	Motor	1
34A	Rear Plate	1
35A	Screw (M5 x 12)	8
36A	Cable	1

## ASSEMBLY DIAGRAM A

NOTE: When referring to the parts shown below, include the letter "A" behind part number(s). Example: Top Plate is p/n 1A.



NOTE: Some parts are listed and shown for illustration purposes only, and are not available individually as replacement parts.

## PARTS LIST B

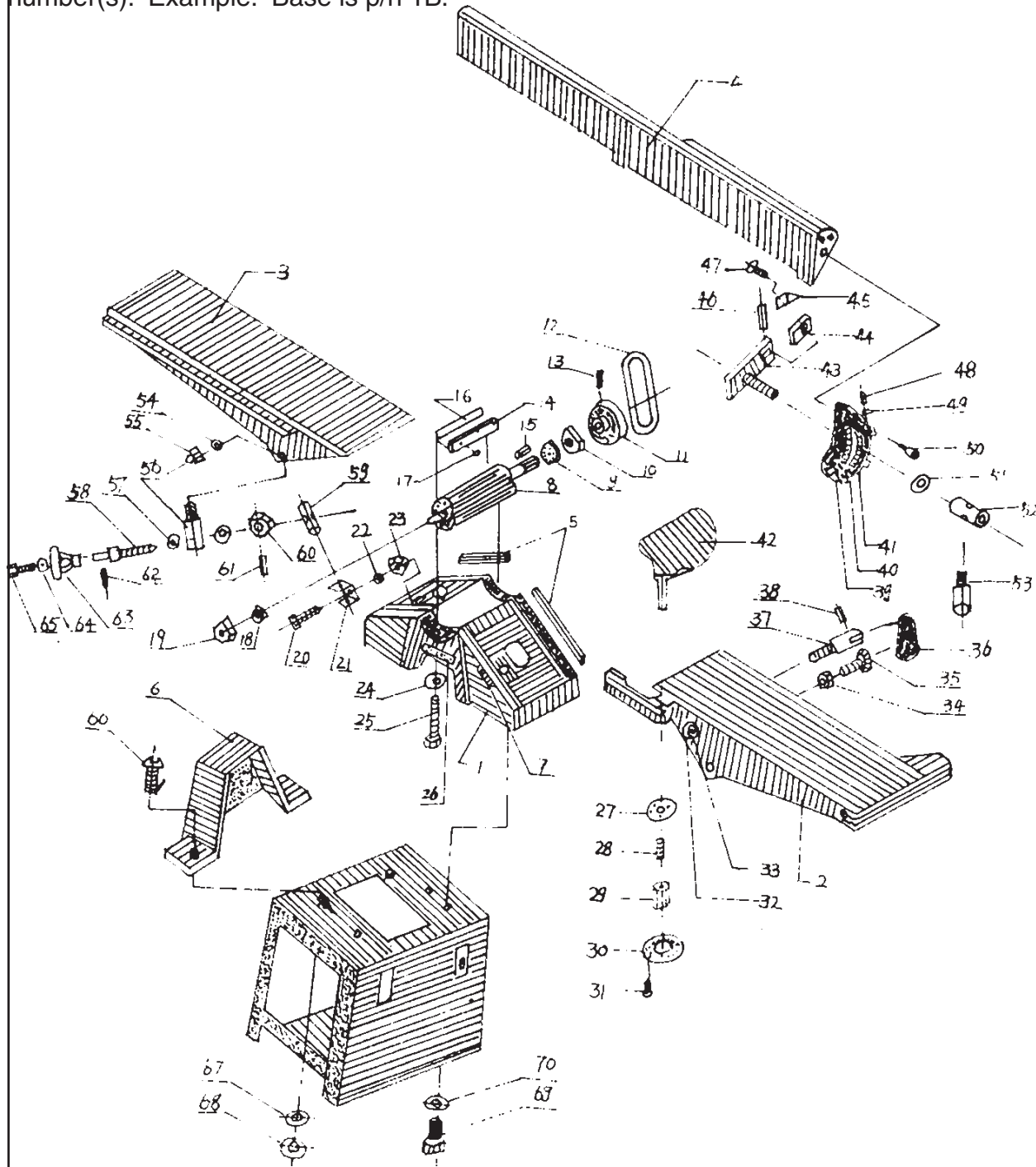
Part #	Description	Qty.
1B	Base	1
2B	Front Table	1
3B	Rear Table	1
4B	Fence Body	1
5B	Gib	2
6B	Belt Guard	1
7B	Depth Scale	1
8B	Cutter Head Assembly	1
9B	Ball Bearing	1
10B	Bearing Housing	1
11B	Pulley	1
12B	Belt	1
13B	Pulley Set Screw	2
14B	Knife Stock Bar	3
15B	Key	1
16B	Knives	3
17B	Knife Set Screw	12
18B	Ball Bearing	1
19B	Bearing Housing	1
20B	Machine Screw	2
21B	Nut Stand	2
22B	Washer	2
23B	Nut	2
24B	Lock Washer	2
25B	Machine Screw	2
26B	Label	1
27B	Retainer Washer	1
28B	Torsion Spring	1
29B	Spring Knob	1
30B	Retainer Ring	1
31B	Screw	3
32B	Depth Ring	1
33B	Screw	1
34B	Nut	4
35B	Adjusting Screw	4

Part #	Description	Qty.
36B	Lock Piece	2
37B	Lock Screw	2
38B	Roll Pin	2
39B	Fence Segment	1
40B	Rivet	3
41B	Tilt Angle Scale	1
42B	Cutter Head Guard	1
43B	Fixed Plate	1
44B	Stop Block	1
45B	Pointer Rod	1
46B	Cotter	1
47B	Screw	1
48B	Screw	3
49B	Nut	3
50B	Socket Cap Screw	3
51B	Washer	1
52B	Jam Nut	1
53B	Handle	1
54B	Washer	2
55B	Lid Nut	2
56B	Shoulder Pin	2
57B	Washer	4
58B	Adjusting Screw	2
59B	Nut	2
60B	Nut	2
61B	Cotter	2
62B	Cotter	2
63B	Adjusting Wheel	2
64B	Washer	2
65B	Machine Screw Hex	2
66B	Pan Head Slotted Machine Screw	2
67B	Washer	2
68B	Nut	2
69B	Machine Screw Hex	3
70B	Washer	3



## ASSEMBLY DIAGRAM B

**NOTE:** When referring to the parts shown below, include the letter "B" behind part number(s). Example: Base is p/n 1B.



**NOTE:** Some parts are listed and shown for illustration purposes only, and are not available individually as replacement parts.

# Wiring Diagram

